



BUTTON ANTENNAS:

Haigh-Farr Button antennas are designed for applications where size and weight are critical. Models cover frequencies ranging from UHF to X-Band, and provide the omnidirectional coverage of a monopole in a rugged package. Models 2107, 2207 and 13215 have a filled-in overhead null, and, therefore, provide the added benefit of full hemispherical coverage.

Haigh-Farr Button antennas utilize proven materials and methods of construction, providing a solid package that requires only one "D" hole in the vehicle for mounting. Superb protection is obtained through the use of a high-impact, high-temperature radome, with excellent properties for environments containing moisture and contaminants.

APPLICATIONS:

Data Links, Telemetry, Transponder
Aircraft
UAVs
Helicopters
Tactical Missiles
Ships
Ground-Based Vehicles
Supersonic aircraft
Single or Array Implementations with Power Dividers and Cables

FEATURES:

Omni-directional Coverage in Azimuth
Overhead Null in Elevation Pattern (Most Models)
Models 2107, 2207, 13215 have the overhead null filled in.
Frequencies from UHF to X-Band
Input impedance of 50 Ohms
Vertical Polarization
Compatible with high power transponders
TNC is the standard connector, with SMA options available
See representative radiation plots on the following page. Additional plots available upon request.
Small, Compact Footprint
High Impact Radome Material
Built to Withstand Extreme Shock & Vibration Environments



CUSTOM ANTENNA DESIGN

Haigh-Farr designs custom antennas to meet customer specifications.



LEVERAGE EXISTING DESIGNS

Haigh-Farr can take an existing design and customize it to meet your application, saving NRE dollars and design time.



IN-HOUSE CAPABILITIES

Manufacturing & testing is done in-house.



PART NUMBERS

Button P/N	Frequency Range GHz	VSWR MAX/TYPICAL	Representative Drawing	Height Inches (mm)	Weight (SMA) OZ (grams)
2107*	5.40 – 5.90	1.5:1/1.25:1	A	0.48 [12.2]	0.9 [26]
2207*	4.40 – 5.00	1.75:1/1.50:1	F	0.63 [16.0]	1.41 [40]
2215	4.4 - 4.95	1.75:1 MAX	F	1.45 [37]	1.4 [40]
2216	5.25 - 5.85	1.5:1 MAX	A	1.3 [33]	0.9 [26]
3106	2.20 – 2.50	1.5:1/1.25:1	B	1.25 [31.8]	1.5max
3106-1	2.0-2.7	2.0:1/1.5:1	B	1.5max	
3107	5.40 – 5.90	1.5:1/1.25:1	B	0.75 [19.0]	1.0 [29]
3107-1	4.40 – 5.00	1.5:1/1.25:1	B	0.95 [24.1]	1.1 ± 0.15
3107S-HP	5.40 – 5.90	1.5:1/1.25:1	C	0.95 [24.1]	1.0 [29]
3108	5.40 – 9.60	2.2:1/1.50:1	B	0.75 [19.0]	1.0 [33]
3108-1	6.40 – 7.20	1.5:1/1.25:1	B	0.75 [19.0]	1.0 [33]
3108-3	8.00 – 10.50	2:1/1.75:1	B	0.75 [19.0]	1.0 [33]
6160-FFF	.350 – .600 [†]	2.0:1/1.5:1	E	6.30 [160.0]	3.5 [99]
6175	0.356 - 0.381	<2.1:1	E	7[177.80]	4.23 [120] MAX
13000T - ER	5.4 - 5.9	1.5:1 MAX	C	.95[24.13]	0.75 [22.3]
13120	0.9 – 1.625	2:1/1.75:1	D	2.69 [68.3]	2.63 ± 0.15[74.6 ± 4.3]
13130	1.4 - 2.7 and 4.2 - 5.85	2.0:1/1.5:1	D	1.81[46.0]	1.9 [55]
13140	2.2 - 6	1.75:1 MAX	D	1.05[26.67]	1.3 [37]
13180	8.0-12.0	2:1 TYP, 3.3:1 max over band	A	.48[12]	1.0 [28]
13190	7.7-11.5	8-10.5 GHz : 1.25 TYP, 1.5:1 MAX 7.7-11.5 GHz : 2.0:1 MAX	B	0.75[19.05]	1.0 [30]
13200	1.4 - 7.0	<1.6:1 typical 1.8:1 max over	F	1.735[44.07]	6 [170]
13210	4.4 - 5.9	1.75:1/1.5:1	D	1.32[33.4]	1.8 [52]
13215*	1.43 – 2.50	2:1/1.5:1	G	1.355 [34.4]	5.1 [144]
13230	1.2 - 1.4	< 2:1 TYP, 2.2:1 max over operating band	G	1.355 [34.4]	5 [135]
13250	1.6 - 2.5	≤ 2:1	D	3.54[89.92]	7.5 oz
13260	4.4 - 5.9	<2:1	D	1.32[33.4]	1.8 oz
13270	4.4 - 5.85	<2:1	D	1.32[33.4]	2.9 [82.2]
16320 - FORE	1.25 - 2.8 3.8 - 5.5	2.2:1/<2:1	C	1.355[34.42]	0.40 lbs. ± .05 lbs.

† The center frequency of model 6160 can be set at the factory to any frequency from 420 to 600 MHz. Maximum bandwidth is 50 MHz.

*Models 2107, 2207, and 13215 feature filled-in overhead null

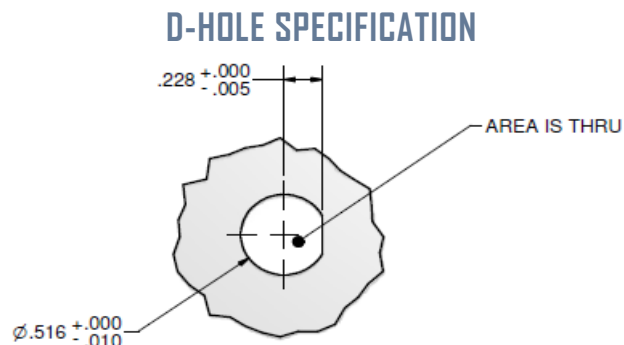

Note: Please confirm D-Hole recommendation at time of order. The above reflects our standard recommendation, but is subject to change.



DRAWINGS

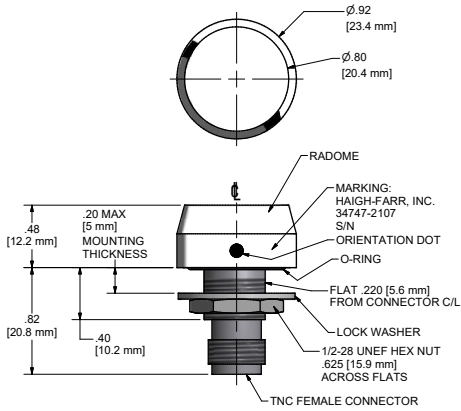

Drawing A

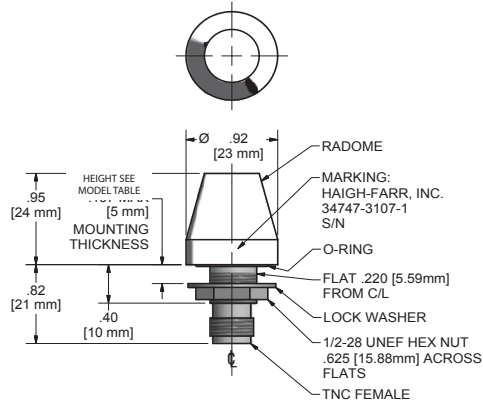

Drawing B

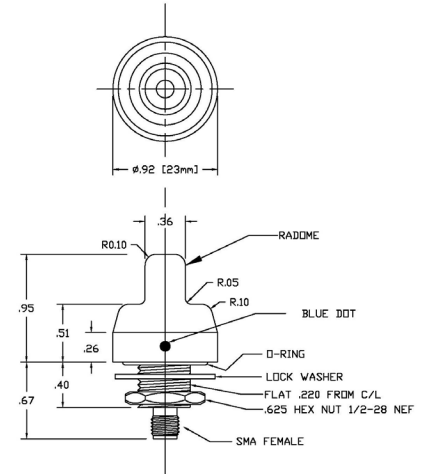

Drawing C

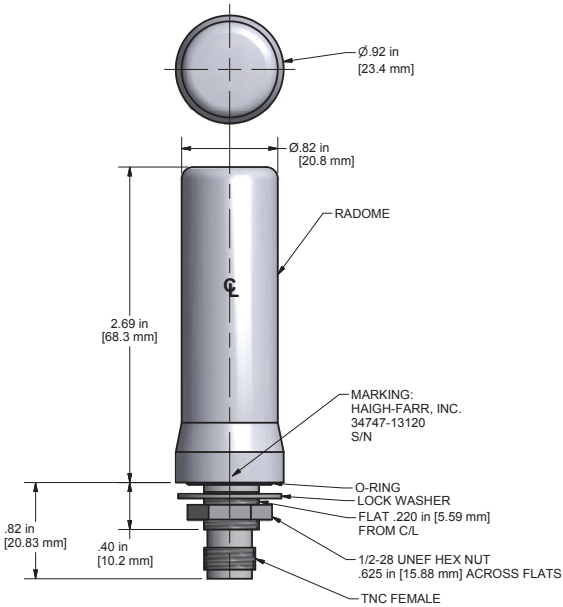

Drawing D

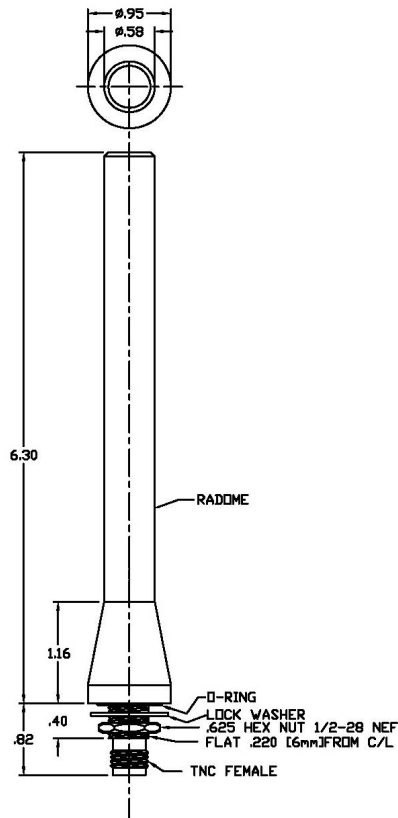

Drawing E

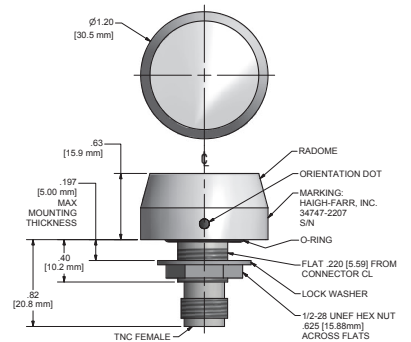

Drawing F

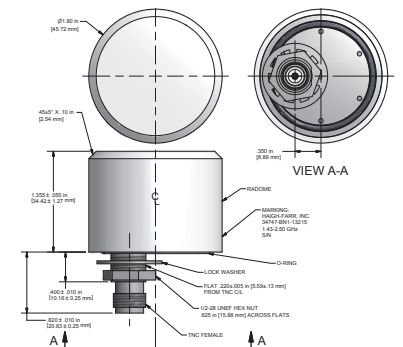

Drawing G



REPRESENTATIVE RADIATION PATTERNS

STANDARD BUTTONS

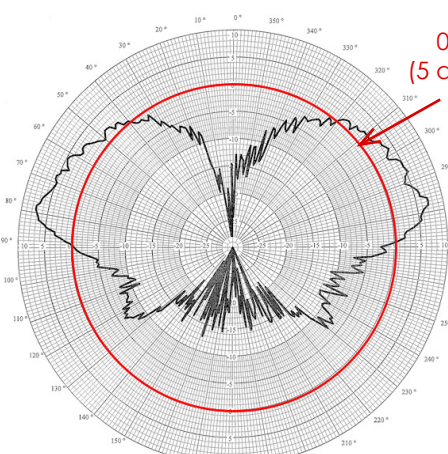

**ELEVATION (PITCH)
5.90 GHz**

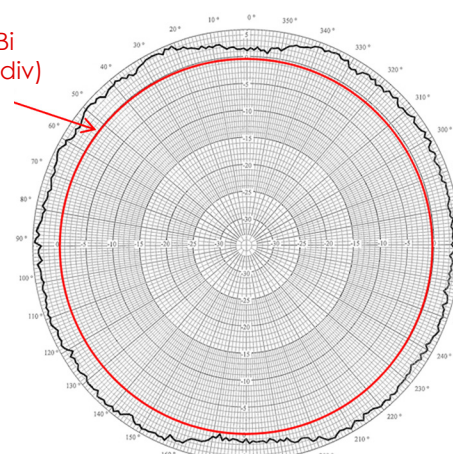

**AZIMUTH (YAW)
5.90 GHz**

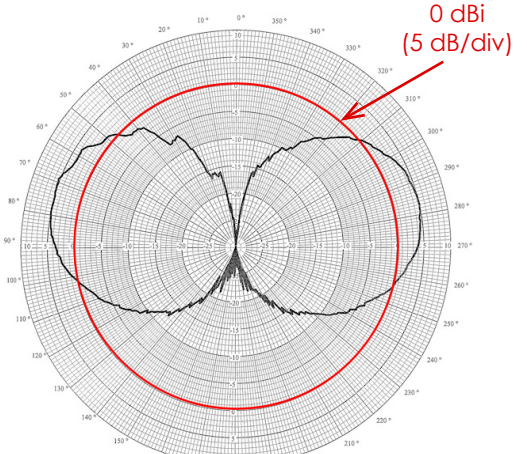

**ROLL
5.90 GHz**

NULL FILLED BUTTONS

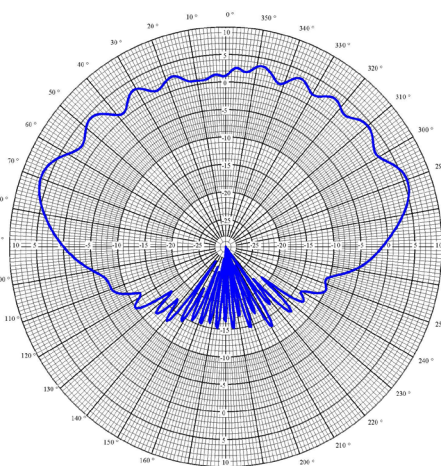

**ELEVATION (PITCH)
4.75 GHz**

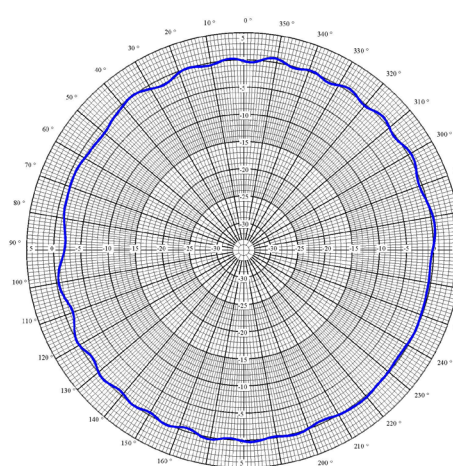

**AZIMUTH (YAW)
4.75 GHz**

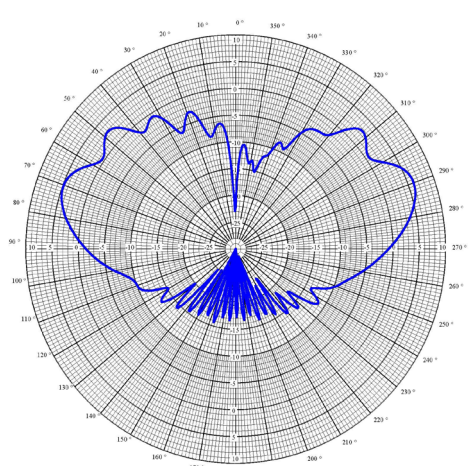

**ROLL
4.75 GHz**

Note: The patterns above were measured with model 3107 mounted on a smooth cylindrical ground plane but are typical of all Button antennas offered. Fins and other protrusions on the vehicle will perturb the radiation pattern. The extent of any perturbations cannot be fully determined until radiation patterns are either calculated or measured on a model of the vehicle. Haigh-Farr offers engineering services, which include the calculation of radiation patterns on a specific vehicle.